

Ecomiser SR-04 / SR-04T DOOR TYPE DISHWASHER



Safety Instructions -----	4-5
Dishwasher Features -----	6-7
Installation Instructions -----	8-14
Machine Operation -----	15-20
Care & Cleaning -----	21
Common Dishwashing Problems -----	22
Troubleshooting -----	23
Customer Service -----	24
Wiring Diagram -----	25-26

Purchase Date: _____

Serial No. _____

Ecomiser SR-04 INSTALLATION REFERENCE

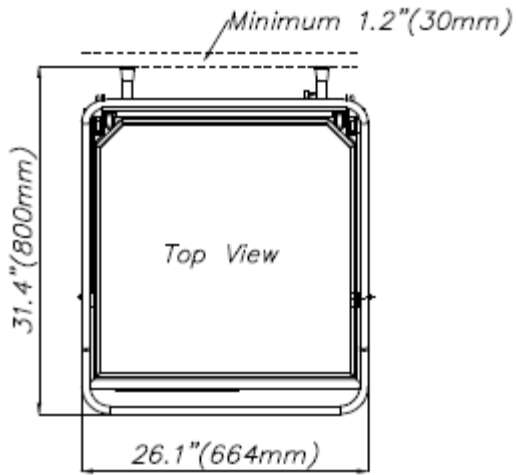

Legend

<i>Height</i>	Door open	71.1" (1,805 mm)
	Door close	55.5" (1,410 mm)
<i>Electric</i>	A	23.7" (603 mm)
	a	8.2" (209 mm)
<i>Water</i>	B	26.9" (682 mm)
	b	6.6" (169 mm)
<i>Drain</i>	C	4.0" (101 mm)
	c	4.7" (120 mm)

⊕ - Electrical supply connection
 SR-04 (208-230 VOLT / 220V/1Ph/23.8 amp)
 (Comes with 6ft(1.8m) cord for direct connection)

W - Hot water connection
 (10psi-40psi(0.7kg/cm²-2.8kg/cm²)
 (Optimum water pressure/ 15psi(1.0kg/cm²)
 (Spray water hardness 5 Grains)
 (Connect to 3/4" male screw)

D - Drain hose connection
 (MAX HEIGHT 18"(457mm))

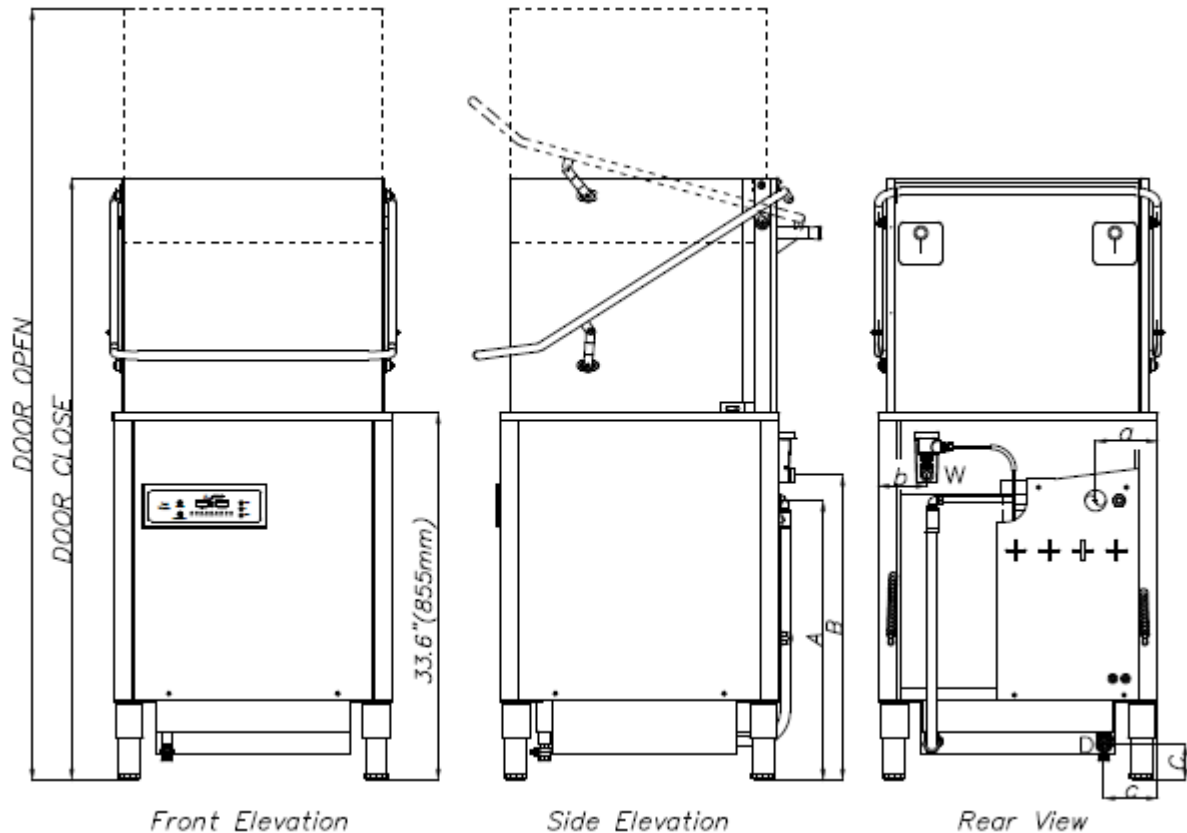

Ecomiser SR-04T INSTALLATION REFERENCE

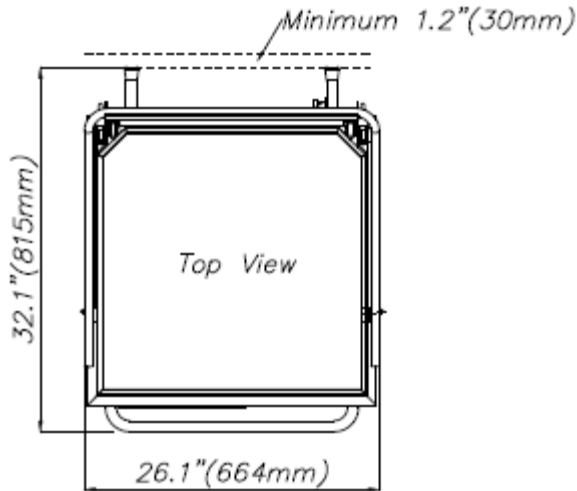

Legend

<i>Height</i>	Door open	95.1" (2,415 mm)
	Door close	68.1" (1,730 mm)
<i>Electric</i>	A	23.7" (603 mm)
	a	8.2" (209 mm)
<i>Water</i>	B	26.9" (682 mm)
	b	6.6" (169 mm)
<i>Drain</i>	C	4.0" (101 mm)
	c	4.7" (120 mm)

⊕ - Electrical supply connection
SR-04T (208-230 VOLT / 220V/3Ph/17.7 amp)
(Comes with 6ft(1.8m) cord for direct connection)

W - Hot water connection
(10psi-40psi(0.7kg/cm²-2.8kg/cm²)
(Optimum water pressure/ 15psi(1.0kg/cm²)
(Spray water hardness 5 Grains)
(Connect to 3/4" male screw)

D - Drain hose connection
(MAX HEIGHT 18"(457mm)

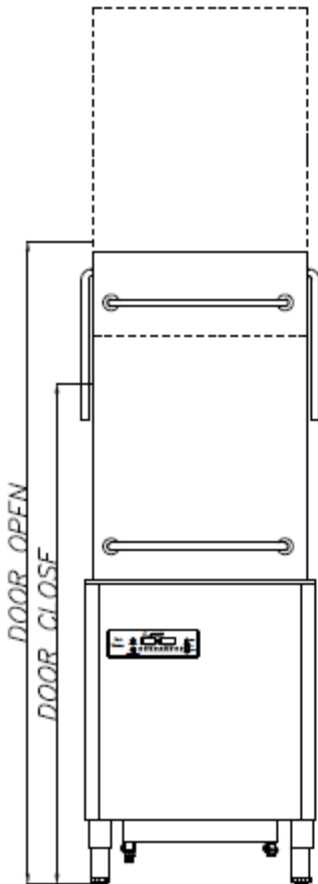

Front Elevation

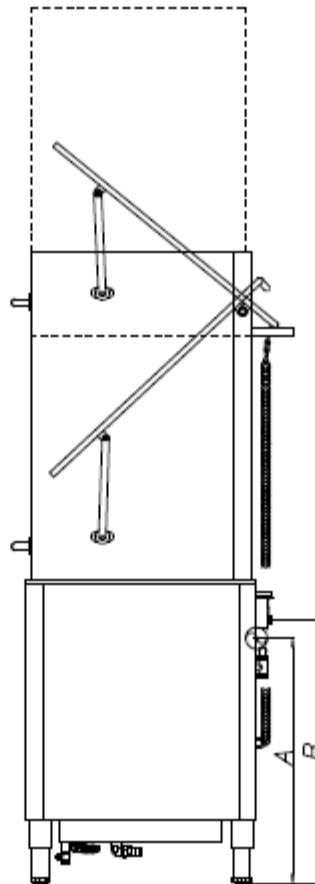

Side Elevation

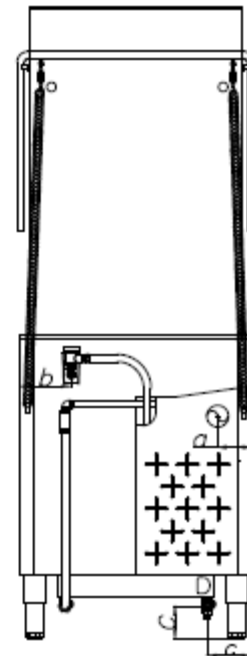

Rear View



Important Safety Instructions

⚠ WARNING

This symbol will help alert you to such dangers as personal injury, burns, fire and electrical shock.

⚠ WARNING

To reduce the risk of fire, electrical shock, or injury when using your dishwasher, follow basic precautions including the following:

Before using the commercial dishwasher, follow the basic safety precautions.

- Read all the instructions before using the **Ecomiser SR-04 / SR-04T Door Type Model** Commercial Dishwasher.
- Use the Commercial Dishwasher only as instructed in this **Owner's Manual**.
- This Manual does not cover every possible condition and situation that may occur. Use common sense and caution when installing, operating, and maintaining the **Ecomiser SR-Model** Commercial Dishwasher.
- The dishwasher must be electrically grounded. Read the Installation Instructions for details.
- The **SR-04 dishwasher is designed to operate on 208 – 230 V, 60 Hz 1 PH and the SR-4T on 208 – 230 V, 60 Hz 3 PH.**
- Do not operate **Ecomiser SR-04 / SR-04T Model** Commercial Dishwasher, unless all enclosure panels are in their proper place.

WARNING

Do not use an extension cord for this machine.

WARNING

The dishwasher must comply with all applicable sanitary, safety and plumbing codes in your area. It is important that at least 1.0 gallon (3.8 liters) per 60 seconds must be supplied to the dishwasher.

WARNING

In order to prevent heat damage to the inlet valve, all solder connections must be made before the water line is connected to the dishwasher.

WARNING

- To avoid entrapment and/or suffocation, remove door or door latch mechanism from any dishwasher that is discarded or not in use.
- Do not abuse, sit, stand or play on door or racks of a machine.
- Use detergents and rinse agents recommended for optimum use in this machine.
- Do not wash plastic items unless marked "dishwasher safe" or the equivalent. Check with manufacturer for recommendations, if not marked. Items that are not dishwasher safe may melt and create a potential fire hazard.
- Disconnect electrical power to machine before servicing.
- Repairs should be done by a qualified technician.
- Do not touch the heating element during or right after use.
- When loading items to be washed:
 - 1) Carefully load sharp items with the handles up to reduce the risk of injuries
 - 2) Do not store or use combustible materials, gasoline or other flammable vapors and liquids in the vicinity of this machine.

Save these instructions for future reference.

NOTE

- Never put animals into the machine.
- Do not wash any kind of food for consumption.
- Do not wash items such as clothes and shoes.
- Do not place any objects on top of the machine.
- Do not close the door before confirming the safety of other people or objects.
- Do not open the door while the machine is operating, because it can cause serious scalds.
- Do not put inflammable items into the machine.
- Do not wash dishware or containers stained with industrial fluid.



Dishwasher Features

Commercial dishwasher is:

- Ecomiser SR-04 208 – 230 V AC / 60 Hz / 1 PH
- Ecomiser SR-04T 208 – 230 V AC / 60 Hz / 3 PH

BASIC FEATURES

Ecomiser SR-04 / SR-04T Door type dishwashers introduce a state of the art patented technology with standard features and benefits currently unavailable in the up-right door type commercial dishwasher market. Adjustable rack capacity and low water consumption that not only reduces operating costs for the end user, but also provides enhanced performance and cycle flexibility. Other unique features include the patented Ecomiser heat exchanger and the advanced programmable controller. This controller simplifies operation and service diagnostics. Equipped with internal electric heaters and powerful rinse and wash pumps provides constant guaranteed temperature and pressure for the wash and final rinse.

All of the above features enable us to minimize water and energy costs, while providing excellence in performance.

FEATURES OF the SR-04 / SR-04T Door Type Model PROGRAMMABLE CONTROLLER Microcomputer technology for service diagnostics and end user dishwasher settings

Microcomputer control panel allows easy selection of three different washing cycles to accommodate different types of ware and levels of soiling. A digital display permits easy monitoring of operation.

- Maximizing washing efficiency and provides a clean environment
- Guarantees proper wash and rinse temperatures
- Controls amount of detergent and rinse agent used
- Controls time of drain cycle
- Auto stop

STANDARD FEATURES

- Variable time cycles (**25 - 207 seconds**)
- Maximum capacity of **40 (for the SR-04T) to 55 (for the SR-04) racks** per hour
- Automatic water fill, automatic start, and automatic stop
- An internal rinse pump ensures that the final rinse pressure is constant and powerful.
- Automatic pumped drain.
- Stainless steel non-clogging wash and rinse impellers
- Movable front mounted **LED** indicator with digital cycle and temperature displays, comes with **3** meter cord.
- All 304L stainless steel construction for corrosion resistance.
- Field-convertible for use in either straight-through or corner applications.
- **3** preset wash cycles → See comment in brochure.
- Drain seals consist of special O-rings that withstand high temperatures.
- Equipped with easily removable, large capacity, one-piece strainer which minimizes frequent removal and cleaning.
- A low-noise and large output 1 hp wash pump is installed for the Ecomiser models SR-04 / SR-04T for reliability and effective operation.
- The door is guided with stainless steel bearings and has a SS spring counterbalanced handle.
- Equipped with revolving, interchangeable upper and lower wash/rinse stainless steel impellers with easily removable nozzles for cleaning and inspection.
- Automatic fill system is used which maintains the correct fill at variable water flow pressures.
- Door activated start.
- Self Service diagnostics.

TECHNICAL SPECIFICATIONS

Ecospeclist04-Rev.06

Manufacturer – Dankor Industries			
Ecomiser Model		SR-04	SR-04T
Optimum Machine Rating (depending on operating conditions)	Racks per Hour	55	40
	Dishes per Hour	1,375	1,000
	Glasses per Hour	1,650	1,200
Overall Dimension (W x D x H, inches)		26.1 (665 mm) 31.4 (800 mm) 55.5 (1,410 mm)	26.1 (665mm) 32.1 (815mm) 68.1 (1,730mm)
Door Open Height (inches)		15.5 (395mm)	27 (685mm)
Water Consumption	Gallon per Rack	0.8 (3.0 L)	1.0 (3.8L)
	Gallon per Hour	43.6 (165 L)	40.0 (152L)
Required Operating Temperature (Room Temp. 64°F/18°C)	Incoming Water	59°F (15°C)	
	For Washing	122°F (50°C)	
	For Rinsing	180°F (82°C) - 198°F (92°C)	
Water Tank Capacity (US Gallon)	Washing Tank	10.7 (40.4L)	
	Rinsing Tank	5.9 (22.5L)	
Electrical Requirements	Specification	208-230/60/1PH	208-230/60/3PH
	Nominal Amp'	220V / 23.8A	220V / 17.7A
	Washing Motor	750W/1PH	750W/3PH
	Rinsing Motor	90W	90W X 2
	Electric Heater	1.5kw X 3	2.0kw (3PH) X 3
	Maximum Power	5.3kw	6.8 kw
Cycle Time	Adjustable/sec	25 - 207	
	3 Optional/sec	65/90/100	90/100/120
Weight	Machine (lbs)	236 (107kg)	264 (120kg)
	Shipping (lbs)	258 (117kg)	286 (130kg)

All specifications are subject to change without notice based on Ecomiser’s dedicated product improvement program.

ACCESSORIES

- Combination rack (1 flat, 2 pin racks)
- 15mm (2.1”) water inlet hose / 5 feet (1.5 m)
- 38mm (1 ½” OD) drain outlet hose / 4 feet (1.2m)



Installation Instruction

INSTALLATION INSTRUCTIONS

Read these instructions carefully and completely before you install the machine. The installation should be carried out by a qualified technician who is familiar with all local codes and ordinances for electrical and plumbing connections. If a commercial dishwasher is being installed in this area for the first time, most of the cabinet work, plumbing, and electrical has to be done before moving the machine into place. In the case of replacing an old dishwasher, check the plumbing and wiring connections before moving the new dishwasher into place. Reasonable access to and around the dishwasher for service must be provided

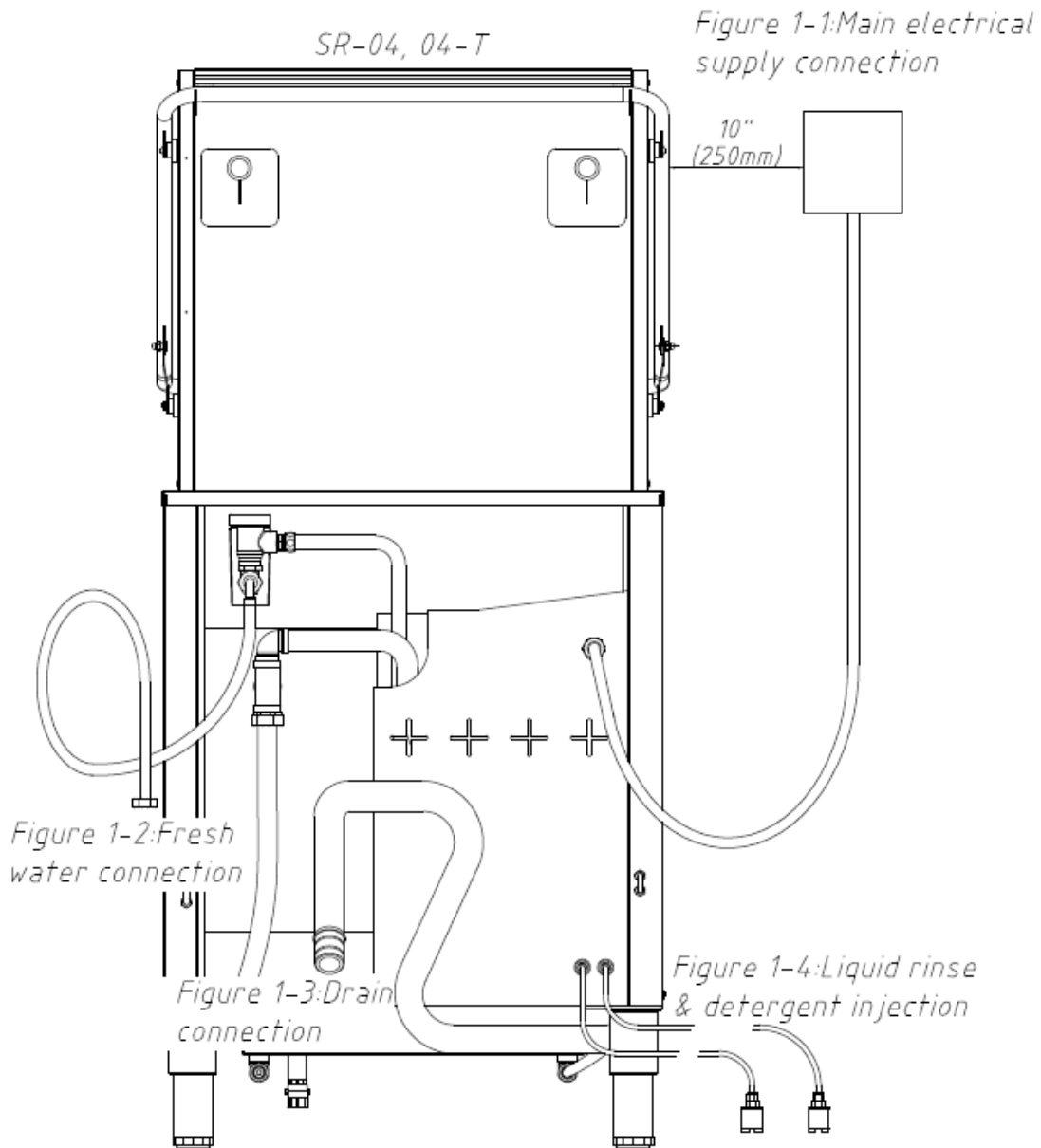

1. ELECTRICAL CONNECTIONS

Connect supply cable with a UL-listed strain relief bushing (if non-metallic cable is to be used).

A **208 - 230 volt, 60 Hz, 1 phase for SR-04 and 3 phase for SR-04T** circuit is required for this machine. Despite the fact that the rating plate shows **220** volts, the unit is designed to function properly on **208 volts to 230 volts**.

- 1) Before working on wiring the machine, be sure the electrical power has been turned off at the breaker/fuse box.
- 2) Electrical and grounding connections must comply with the applicable portions of the national electrical code and/or other local electrical codes.

GROUNDING INSTRUCTIONS

This machine must be properly grounded. Grounding instructions for a permanently connected machine:

- This machine must be grounded to operate properly. It must be connected to a grounded metal, permanent wiring system or an equipment-grounding conductor must be run with the circuit conductors and connected to the equipment-grounding terminal or lead of the machine. When grounding the machine, connect the green line to the terminal provided.

Figure 1-1 Main electrical supply connection

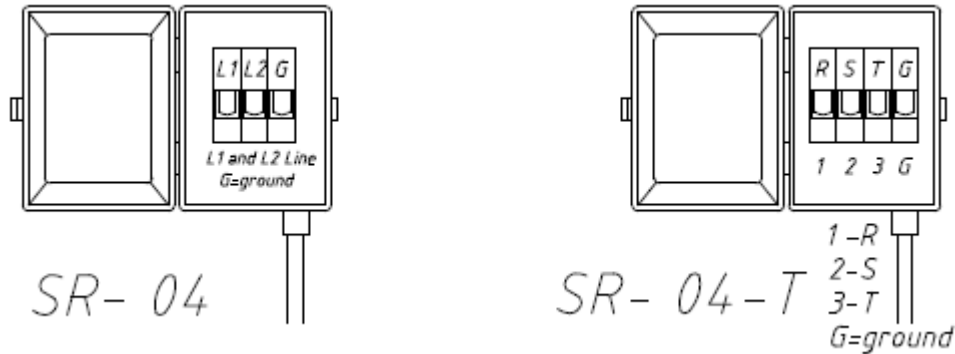

OVERVIEW OF INSTALLATION

The owner should contract with qualified personnel to move the appliance to the installation location, unpack it, and prepare it for final utility connections. In most cases, local codes prevent the final utility connections from being made by any party other than a licensed electrician and plumber.

NOTE

It is the responsibility of the owner to ensure that all aspects of the installation comply with all applicable local and national codes.

NOTE

It is a good idea to inspect for any shipping damage before you proceed with the installation. If you find any damage, you should report it to your dealer / freight company before accepting delivery.

2. WATER SUPPLY LINE CONNECTION

Before connecting the water supply hose, the line must be flushed clean of all debris, including (but not limited to) pipe sealant, metal particles, solder, etc. This debris can damage to the machine.

- The water supply line could be connected to hot water or cold water and a shut-off valve should be installed before connecting them.
- Water supply pressure should be under **40 psi** and temperature should be kept at a minimum **59°F/15°C**. Adjust water supply time to 1 gal per cycle, using the water flow control valve inside the machine. Adjust so the fill indicating light stays on for 30 seconds.

Figure 1-2 Fresh water connection

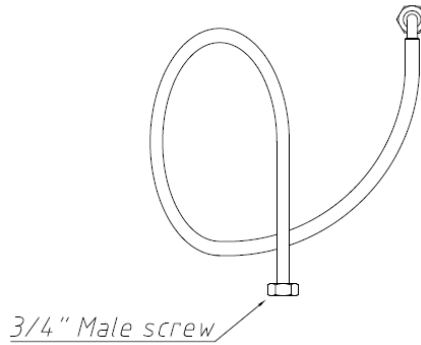

NOTE

In some cases, local codes dictate that water supply connections be made only by a certified professional.

- Check that iron or other metal particles cannot contaminate the fresh water supplied to the machine.
- Check that the incoming water pressure is within the acceptable range for the machine (**10 - 40 psi, 0.7 - 2.8 bars**). It may be necessary to reduce the pressure.
- Check the incoming water temperature. Colder water will result in a longer preheat time (during initial startup) and may extend the cycle time to allow the final rinse water to heat to minimum **180°F/82°C**.
- Check the incoming water hardness. The Ecomiser SR-04 / SR-04T Models require a hardness of 4 grains per U.S. gallon or less. If over 4 grains the water should be treated.
- When connecting the customer-supplied water line to the fitting on the end hose supplied, pay attention to prevent the hose from being twisted or broken.

3. DRAIN CONNECTIONS

- The Ecomiser SR-04 / SR-04T models contain a **1 1/2" (38mm OD)** drain hose for end user's convenience.
- The Ecomiser SR-04 / SR-04T models are factory built with a drain pump. Recommended rough in height is maximum **18" (457mm)**.
- Check that the end of the drain hose will empty into a drain with a minimum diameter of **1 1/2" (38mm)**.
- Route the drain hose to the drain. In some cases a grease trap (supplied by others) must be fitted into the wastewater line. If this trap is required for your installation, check that it is present.

Figure 1-3 Drain Connection

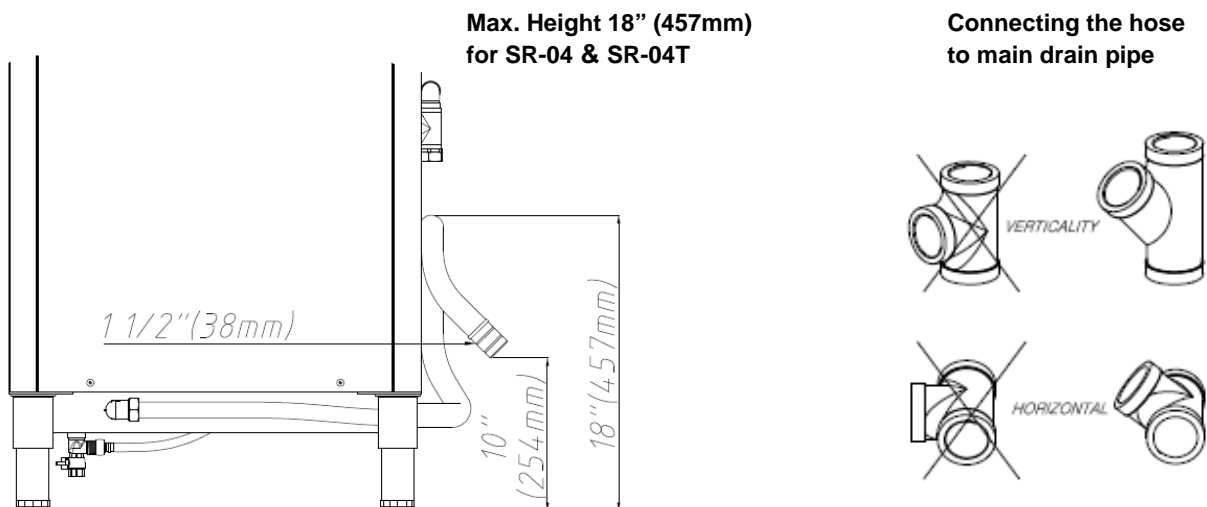

NOTE

- No portion of a wall drain system may be higher than **18" (457mm)**.
- No part of the drain hose should be higher than **20" (508mm)** from the bottom of the dishwasher.
- Failure to provide the proper drain connection height (**maximum of 20" (508mm)**) above the bottom of the dishwasher base) will result in improper drainage.
- After connecting the drain hose to main drain line, make sure all connections are watertight

4. DISPENSING SYSTEM CONNECTION

The Ecomiser SR-04 / SR-04T models are designed for use with a liquid rinse aid and detergent. The Ecomiser SR-04 / SR-04T models equipped with liquid internal detergent and rinse aid pumps each have each tube exiting the machine at the lower rear. These tubes can simply be attached to detergent and rinse aid containers.

- Commercial (not a domestic) detergent must be used.
- Locate the red liquid detergent and blue liquid rinse aid tube at the lower rear of the machine. Connect the tubes to the detergent and rinse aid container.

Figure 1-4 Liquid rinse & detergent injection

This figure shows you how tubes are to be connected to detergent / rinse containers.

- a) Make a hole about 3mm bigger than the tube diameter on the container cap (No. 1)
- b) Insert the tube through the container cap into the sinker cap (No. 2)
- c) Tighten the sinker cap on to the sinker (No. 3)
- d) Drop the sinker down to the bottom of the container to supply chemical properly.

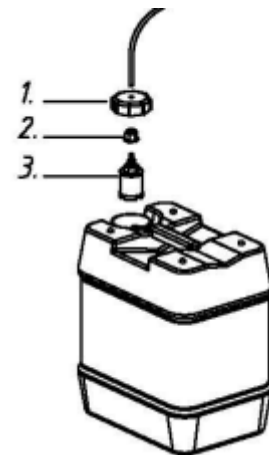

5. TO PRIME DETERGENT AND RINSE AGENT PUMPS

This mode will only work if the **READY LED** light is on.

- 1) Detergent** - While the power is turned on, press **MODE** and **UP** button simultaneously to supply detergent.
- 2) Rinse Agent** – While the power is turned on, press **MODE** and **DOWN** button simultaneously to supply rinse agent.

6. STRAIGHT-THROUGH AND CORNER TABLING CONFIGURATIONS

The Ecomiser SR-04 / SR-04T models would be installed by straight-through and corner tabling configurations as per the following diagrams:

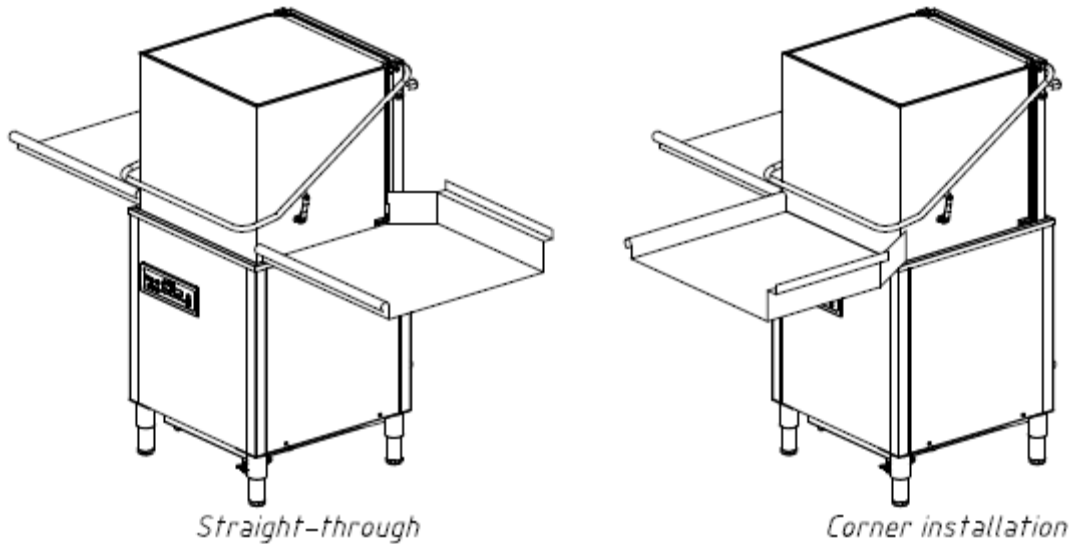

CAUTION

Installation work should be done by certified technicians. Before setting up the machine and tables, check first whether power line, drain line, water supply line and detergent/rinse tubes are connected properly.

6.1 The straight-through installation

- Before hooking up plumbing and power lines, install the machine in the desired location and level using the feet. Run the detergent/rinse lines to where the chemical containers are located.
- After connecting the table to the machine, check that the door is moving up and down without any interference between the machine and the table.

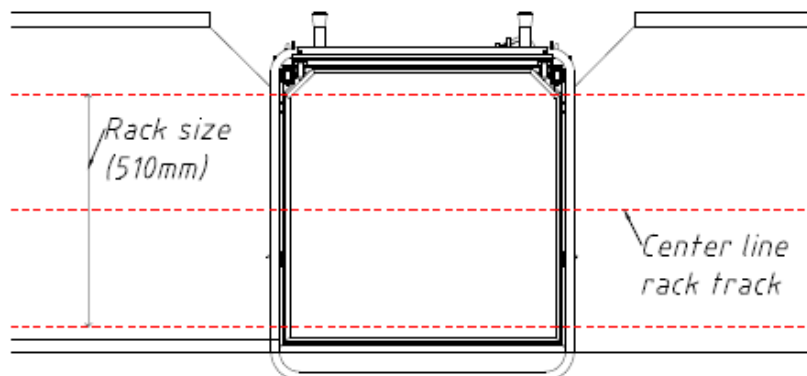

Straight-through

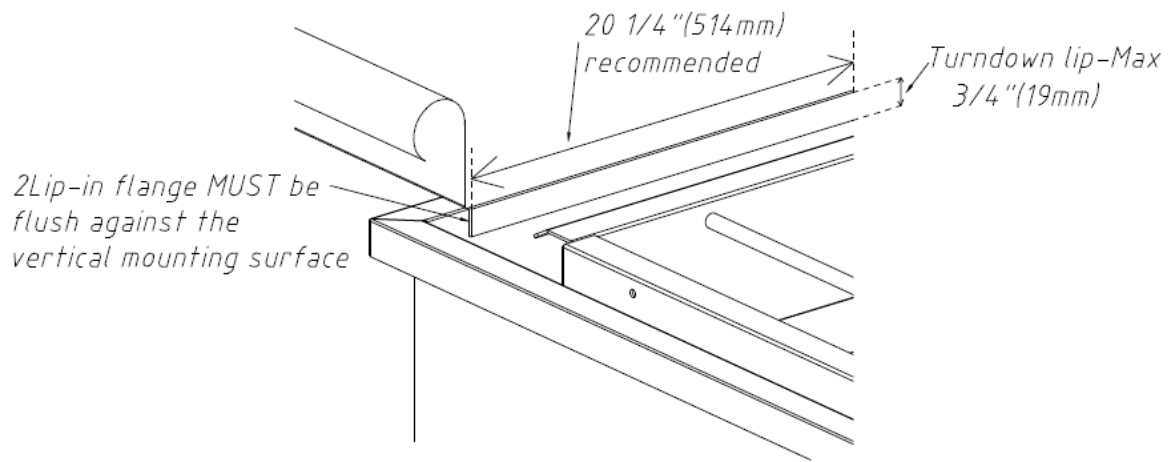

6.2 The corner installation

- For a corner installation only, move the rack guide rail from the front position to the side position.

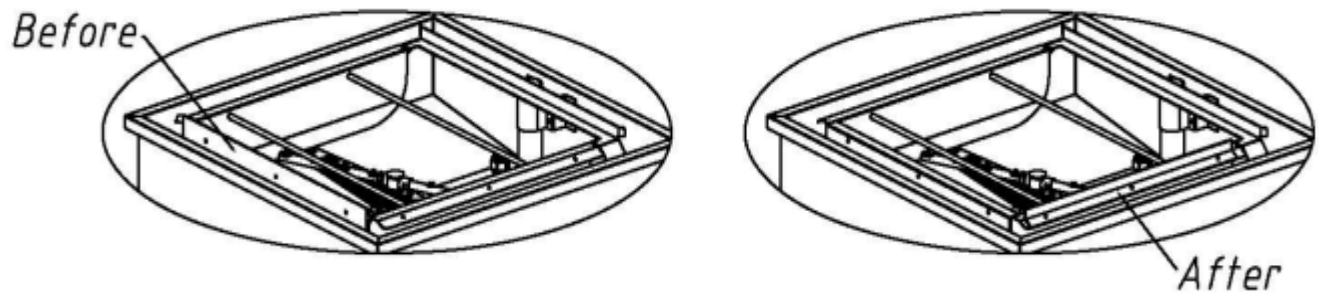

- Align the table centerlines with the machine.
- Next figure shows a door handle clearance for corner installation.

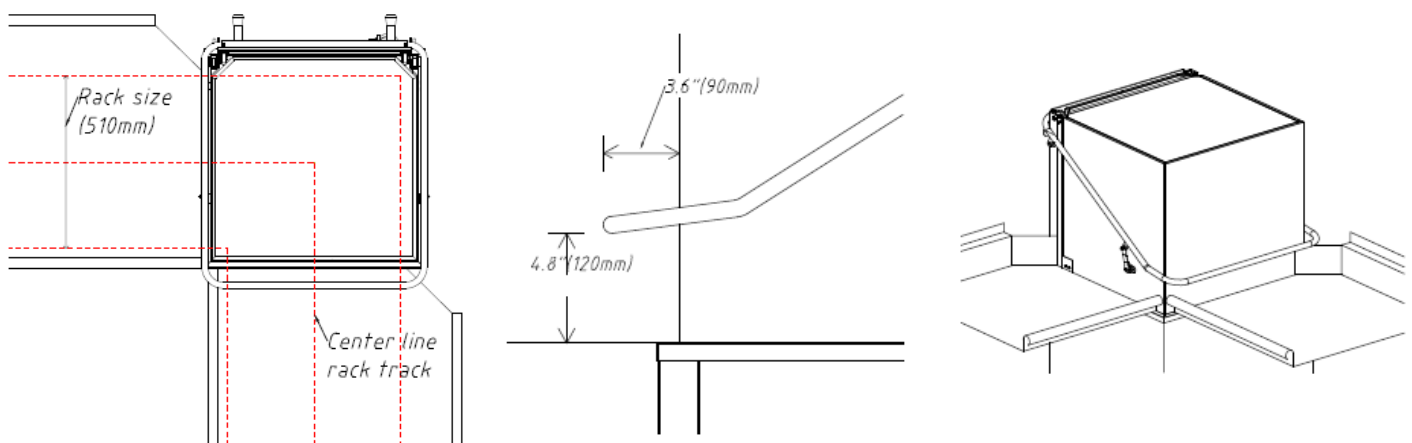

- When installing the machine at the corner, its right side should be stood facing to a wall for easy maintenance.
- Optional side panel should be installed before setting machine in place

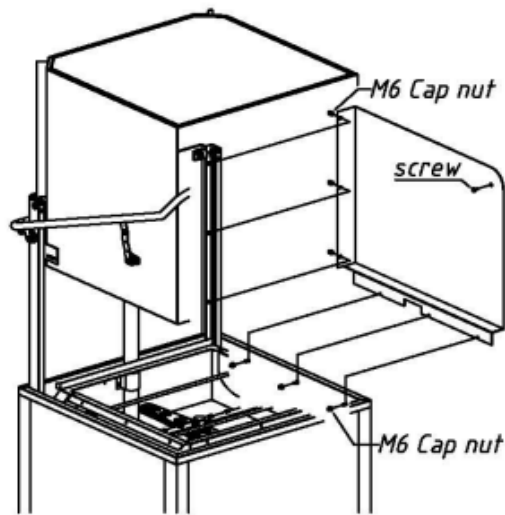

After setting the machine in place, you have the option of relocating the control panel to a bracket installed beneath the dish tables or on the wall (optional brackets supplied by others). Display bracket should be located 10" (250mm) away from the machine.

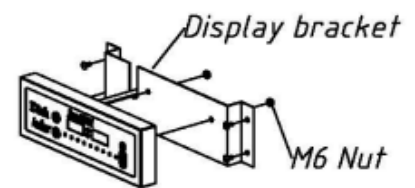
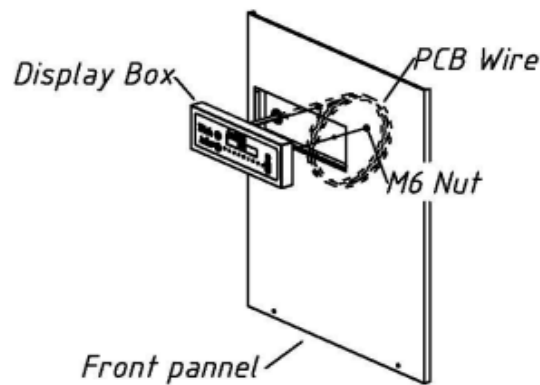
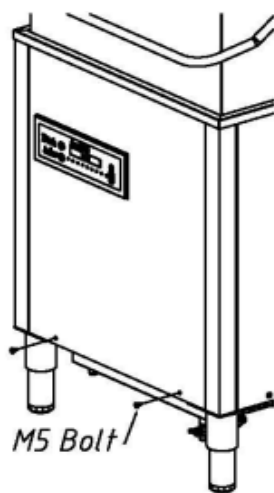



Machine Operation

IMPORTANT SAFETY INSTRUCTIONS

WARNING

Before using the machine, follow basic precautions including the following:

- Read all instructions before using dishwasher.
- Use dishwasher only as instructed in this manual.
- This manual does not cover every possible condition and situation that may occur. Use common sense and caution when installing, operating and maintaining any appliance.
- Do not operate dishwasher unless all enclosures panels are in their proper place

NOTE

Before using the machine, read the manual and keep it in a convenient place for review.

- Open the water supply valve.
- Turn the power on after turning on the breaker
- Water will be filling in the tanks, but filling time of the water depends on the water supply pressure.
- When the tank is full and the water has been heated to the preset temperature, the **READY LED** lamp on the front control panel will be on. The machine is now ready for operation. Cycle can be started by either pushing **START** button or opening and closing the door.

OPERATION

- 1) Push power button or open and close door to turn on.
- 2) Remove and clean strainer basket as necessary. Remove any large food particles, scraps, sticks or bones from the strainer basket. Lift out the strainer basket and clean it thoroughly using a brush and warm water.
- 3) End of day push **POWER** button to turn off. The machine will automatically enter a self cleaning cycle when it is turned off. The interior will be sprayed with hot, fresh water for 10 seconds.

NOTE

The daily cleaning is a general recommendation based on typical soiling. Because of large quantity of food soiling on many dishes, pots and pans, at times it may be necessary to clean the machine more often and more extensively. Extensive food soil deposits inside the machine work against optimal performance. Some items may not be cleaned as effectively, resulting in the need for either a longer cycle or repeat washing.

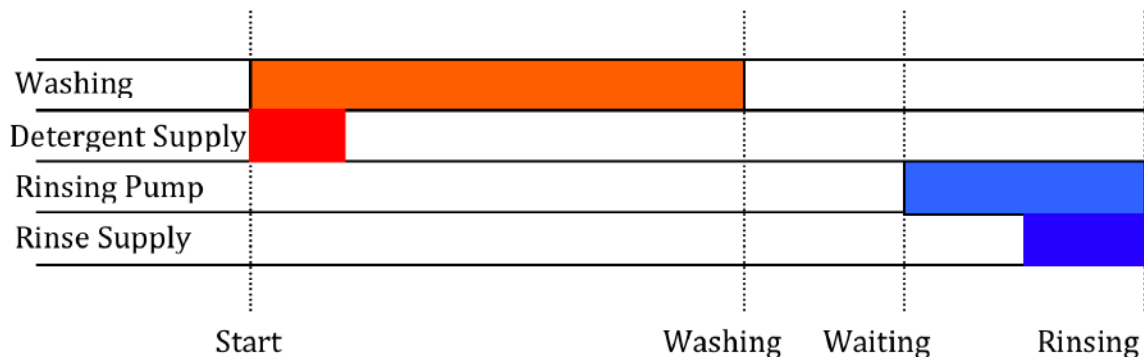

CONTROL SYSTEM

1. Configuration of Display

The display controller on all door machines can be mounted remotely, within 3 meters of the machine.

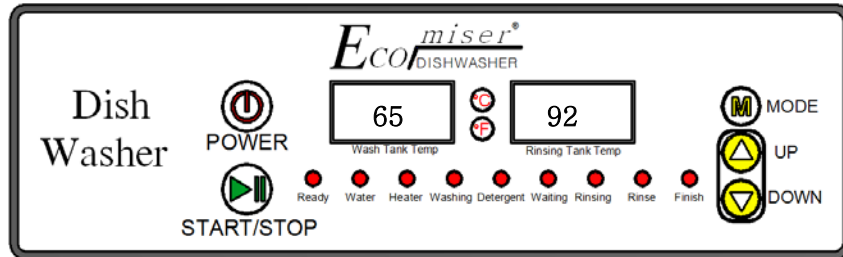

2. Windows Displays

2-1 Wash Tank Temperature

- 1) Displays the temperature of the wash tank, and **RUN** message.
- 2) Displays **SETTING** when **MODE** button is pressed.

2-2 Rinse Tank Temperature

- 1) Displays the temperature of the rinse tank, and **NUMBER** message.
- 2) Displays the temperature of the rinse tank during wash cycle.
- 3) Displays the menu for **SETTING** when **MODE** button is pressed.
- 4) Displays **ERROR** message.
- 5) Displays **END** message for 30 seconds after the cycle is completed. Message is cleared as soon as the door is opened.

3. LED

3-1 Ready

Indicates that the cycle is fully ready. If the temperature requirement (Rinse Tank: **82°C** or **180°F**, Wash Tank **50°C** or **122°F**) is met, the message will be shown. When the **READY LED** is not turned on, none of the buttons will work.

3-2 Tank Fill

- 1) Water will be supplied until both of the **FLOAT** switches are activated in both the rinse and wash tank.
- 2) **LED** will be turned on while the water is being supplied.
- 3) During the wash cycle, even if the **FLOAT** switch is turned off, water will not be replenished.

3-3 Heater

- 1) Will depend on the temperature settings.
- 2) When heater is working (FLOAT SWITCH ON/OFF status)

Process	Rinse Tank Lower	Rinse Tank Upper	Wash Tank	Heater Operation
Step 1	OFF	OFF	OFF	OFF
Step 2	ON	OFF	OFF	ON
Step 3	ON	ON	OFF	ON
Normal	ON	ON	ON	ON → OFF → ON, Repeat

- 3) Depending on the temperature inside the lower and upper rinse tank, the switch will go ON/OFF.

3-4 **Cycle LED:** Will display during cycle. (Washing, Detergent, Rising, Rinse Agent, Finish)

- 1) Washing
 - If the door is opened then closed, wash cycle will begin within 2 seconds
 - While the door is closed, press **START/STOP** button to initiate the wash cycle.
 - While **READY LED** is turned off, machine will not operate.
 - After each cycle is completed, it will move in sequence.
 - If **FLOAT SWITCH** is turned off before the wash cycle begins, **LED** will not work.
- 2) Detergent
 - At programmed time, detergent will be supplied.
- 3) Waiting
 - After the wash cycle, machine will be put into waiting mode
 - Machine will stop for previously set time
- 4) Rinsing
 - Rinse cycle is in operation.
 - After programmed time, rinse cycle will end.
- 5) Rinse Agent
 - At programmed time, rinse agent will be supplied.
- 6) Finish
 - When the rinse cycle is finished, the **WHOLE CYCLE** is finished.
 - **FINISH LED** will light up.
 - End message will appear.
 - After the finish buzzer sounds (3 Times), for 30 seconds on the **DISPLAY**, the **END** message will appear.
 - After 30 seconds machine will reset to the beginning

3-5 **Temperature Display – °C or °F** (Celsius or Fahrenheit)

4. Power

4-1 **POWER Button**

- 1) Turns the power ON.
- 2) While the power is turned OFF, everything is stopped.
- 3) While **ERROR** message is displayed, press the power button to clear the message.

4-2 **START/STOP Button**

- 1) Button is used to start and/or stop the whole cycle.
- 2) If cycle is interrupted by opening the door, the message **PAU** will be displayed. Immediately press the **START/STOP** button to cancel message when the door is closed.
- 3) **START/STOP** button will stop any ongoing cycle.
- 4) **START/STOP** button will manually stop the **DRAIN CYCLE** after the power is turned off.

4-3 **Mode Button**

(Press and hold the button for 7 seconds to initiate **MODE**) If there is no activity for more than 3 seconds, you will exit the **MODE** function.

- 1) Press **MODE** button 1 time → Configure **WASH** cycle duration
- 2) Press **MODE** button 2 times → Configure **DETERGENT** cycle duration
- 3) Press **MODE** button 3 times → Configure **WAIT MODE**
- 4) Press **MODE** button 4 times → Configure **RINSE** cycle duration
- 5) Press **MODE** button 5 times → Configure **RINSE AGENT** cycle duration
- 6) Press **MODE** button 6 times → Configure **HIGH** temperature
- 7) Press **MODE** button 7 times → Configure **LOW** temperature
- 8) Press **MODE** button 8 times → Configure **BUZZER** on/off setting
- 9) Press **MODE** button 9 times → Switches temperature display between **°C & °F**
- 10) Press **MODE** button 10 times → Displays **DRAIN** cycle duration (DIP Switch UC only)
- 11) Press **MODE** button 11 times → Displays Model Number
- 12) Press **MODE** button 12 times → Returns to beginning

4-4 UP/DOWN Arrow Buttons

- 1) Within each mode, it will display time, temperature and selections.
- 2) **UP/DOWN** buttons will increase or decrease certain variables.
- 3) When the system is not set in **MODE**, **UP/DOWN** buttons will display time remaining in cycle.
- 4) When the machine is not running, **UP/DOWN** button will display wash time duration (65/90/120 seconds).

4-5 TEMPERATURE LOCK/UNLOCK

While the power is turned OFF, press DOWN + UP + START/STOP button simultaneously for 3 seconds to initiate PCB LINE TEST MODE. Lock/Unlock temperature restriction of 82°C for rinse tank, and 50°C for wash tank

5. Power Breaker ON

- 1) Provides power source to the machine. (Breaker **ON**)
- 2) On initial installation start up, when power is provided by the breakers, the machine will make an initial long buzzer sound.

6. Operation

POWER button will initiate water supply, and as the water level reaches different levels, heaters will be initiated. The machine will start the initiation stage where water temperature will be heated up until it reaches the pre-set temperature.

6-1 Initiation Stage

- 1) If the water temperature in the rinse tank reaches 92°C (198°F) and wash tank reaches 55°C (131°F), initiation stage is completed. The **READY** lamp will be turned on.
- 2) Not meeting the initiation stage requirement:
If the temperature in the upper level rinse tank reaches 92°C (198°F), rinse cycle will initiate once, and if the temperature is below that of 92°C (198°F), the machine will not initiate until this temperature is reached.

6-2 During Initiation Stage

- 1) Washing, Rinsing, Detergent: 10 seconds
- 2) Washing: 80 seconds
- 3) Rinsing: 10 seconds
- 4) If the door is opened during initiation stage, it will cancel the cycle.
- 5) Press **POWER** button to stop the initiation stage.
- 6) If initiation stage is cancelled, [RUN]/[00],[00]/[00] message will appear in 2 second intervals.

For example:

[run / 100]: Cycle time: 100 seconds

[65 / 90]: Wash tank temperature: 65°C, Rinse tank temperature: 90°C

6-3 POWER OFF

- 1) Water will start to drain out.
 - Drain pump: 90 seconds
 - Rinse pump (cleaning process): 10 seconds
 - Wait: 10 seconds
 - Drain pump re-initiation: ON (30 seconds) → OFF (5 seconds) → ON (5 seconds) → OFF (5 seconds) → ON (5 seconds)
- 2) Press START/STOP button during water drain stage to stop the cycle and the machine completely.

7. ERROR MESSAGE

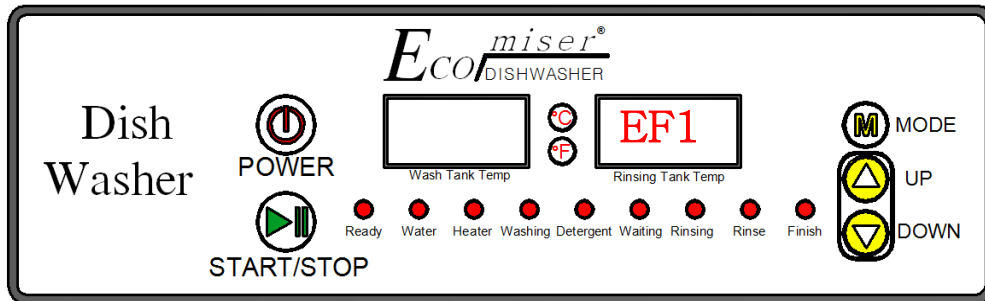

1) Er1

While displaying temperature above 110°C (230°F) check wash temperature sensor operation and for short.

2) Er2

While displaying temperature above 110°C (230°F) check upper rinse tank temperature sensor operation and for short.

3) Er3

While displaying temperature above 110°C (230°F) check lower rinse tank temperature sensor operation and for short.

4) EF1

Water supply ERROR, problem with Rinse Tank FLOAT SWITCH, displays if there is no signal from FLOAT SWITCH, 15 minutes into the water supply.

5) EF2

Water supply ERROR, problem with Rinse Tank FLOAT SWITCH, displays if there is no water supply for more than 40 minutes, when the water supply is initiated.

6) Ed1

Upper OVERFLOW FLOAT SWITCH ERROR, displays if upper OVERFLOW FLOAT SWITCH is turned on.

7) Miscellaneous

7-1) Displays if there is any type of ERROR, machine will completely stop.

7-2) ERROR buzzer will sound 5 consecutive times.



7-3) POWER button or START/STOP button will clear the ERROR status, but unless the ERROR is fixed, ERROR MESSAGE will continue to display.

8. SETTING DATA

1) When the machine is turned off, all pre-set data will be saved.

2) Pre-set data consists of wash time / detergent time / wait time / rinse time / rinse agent time, temperature setting, buzzer sound, temperature unit, and model number.

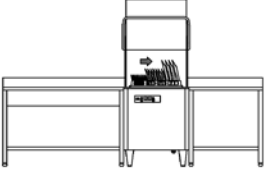
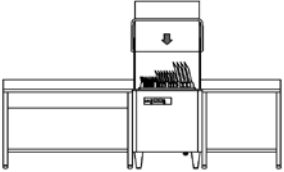
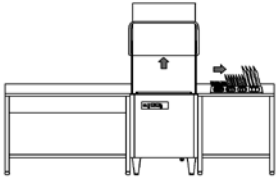
Pictures below show loading racks from left to right, but racks can be loaded from any direction:

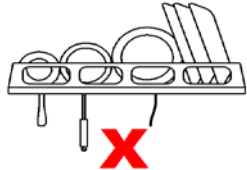
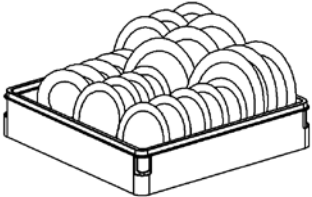
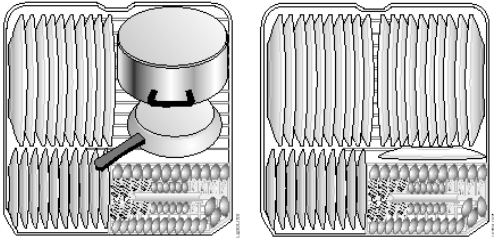
<p>First prepare the rack loaded with dishes then push up the door</p>	
<p>Gently push the rack to the inside guide of the machine</p>	
<p>Push down the door then the machine starts after 3 seconds</p>	
<p>When alarm sound begins, push up the door and take out the rack</p>	
<p>Don not forget that the bowls, spoons, etc., are not to be stacked closely, so as not to affect washing and drying performance.</p>	
<p>Do not let little objects like spoons, forks, chopsticks or knives stick out of the gaps between racks. It could deteriorate the performance of the machine and could damage it.</p>	
<p>Organize trays and plates on their side. Organize in a way so the large dishes are on the outside, and the small dishes are inside of the rack. It will increase the machine's performance.</p>	
<p>When dishware is well organized, better performance in productivity can be achieved per rack.</p>	



Care and Cleaning

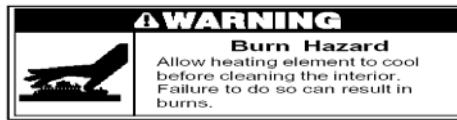

The interior of the Ecomiser SR-04 / SR-04T models are made of quality stainless steel that has been electro polished to produce the smoothest surface available. The smooth surface prohibits the accumulation of dirt and bacteria inside the unit. If the water in your area is especially hard, however, lime deposits could form inside the machine. If this happens, you can remove them by putting **1000cc** of scale removal product in the wash tank and running a normal wash cycle **10 times**. In extremely hard water areas you may need to repeat this process a few times to remove hard water deposits.

CLEANING THE STRAINER BASKET

For your convenience, we have placed the strainer within easy reach inside the tub. To clean the strainer, wash it gently in hot, soapy water and rinse it thoroughly **1 to 2 times every day**.

CLEANING THE DOOR

To clean the edge around the door, use only a soft warm, damp rag. To prevent penetration of water into the electrical components, do not use a spray cleaner of any kind.

WARNING

Never use a spray cleaner of any kind on the control panel. You could damage the electrical components. Never use abrasive cleaners or scouring pads on the outer surfaces because they will scratch the finish. Also, some paper towels can scratch or leave marks on the stainless steel surface.

CLEANING THE IMPELLERS

Impellers may sometimes become clogged with hard water deposits. To remove them, grip the center of impeller and wash it all over with soft rags. After removing all of the impellers, check to ensure impellers revolve easily.

DE-LIMING

Lime scale deposits will occur over time on the interior of the machine if it is operated using a hard water supply. The Ecomiser SR-04 / SR-04T models require that a de-liming or de-scaling process be used to remove these deposits, as well as any accumulated food residue. When de-liming the interior area, be sure to follow these guidelines.

- Use de-liming agents designed for use with commercial dishwashers.
- Follow the instructions for the de-liming agent that is used.

NOTE

After the de-liming process:

- Run the machine through **2-3** regular cycles and sanitize the interior thoroughly.
- Inspect the interior for any remaining de-liming agent residue. If residue is present, remove it using a soft cloth and hot water; then, run the machine through one final cycle.
- Press the **POWER OFF** button. This will empty the tank, ensuring that any de-liming agent still in the tank will be flushed out of the machine.
- Ensure that all residue of the de-liming agent is removed. Residue from the agent can pose a health hazard and damage seals and plastic components inside the machine.



Common Dishwashing Problems

As with any new machine, it sometimes takes using it a few times to learn to operate it properly. If you are having minor performance problems with your dishwasher, read this section before calling for service. It may save you time and unnecessary expense.

POOR WASHING PERFORMANCE

- The dishes may not be loaded properly. Make sure that soiled surfaces are facing downward or toward the center of the dishwasher. Also, make sure that the bowls, pots, etc., are not stacked so closely that water can't reach the soiled surfaces.
- Make sure you are using the appropriate program settings for the dirtiness of the dishware.
- An item may be obstructing the rotation of the impeller. With the rack loaded and in place, manually turn impellers to ensure free movement.
- Dishwasher detergent should be fresh and stored tightly closed in a cool, dry place. Old or caked detergent will not dissolve properly.
- Dishwasher detergent may be inferior. Try a different brand.
- If you have hard water in your area, try adding more detergent and increasing the amount of rinse aid dispensed. Water hardness must be controlled to **4-6** grains for best results.
- Check that the impeller jets are not clogged.

POOR DRYING PERFORMANCE

- Make sure the rinse aid is enough.
- Do not overload the dishes and be careful to avoid nesting.
- Load items with concave bottoms tilted so as much water as possible will run off.
- Dishes washed in higher water temperatures will dry faster.
- Certain plastics may need to be towel dried. Always check the manufacturer's suggested care instructions before washing plastic in your dishwasher. Even dishwasher-safe items should be loaded in the rack, away from the heating element.
- Check the amount of rinse aid is proper that it is fresh.

WASHING ITEMS

Ecomiser has no control over what is put in dishwasher once installed in a user's place. You are solely responsible for what you wash in your **Ecomiser SR-04 / SR-04T models** dishwasher. Most common dishware items can be safely washed in an automatic commercial dishwasher. If you have any doubts about a particular item, check with the manufacturer to see if it is dishwasher safe.

- Some high-acid foods can discolor plastic. You should rinse these items.
- When you load the dishware, be sure dishware is securely in place and will not fall over or strike against each other during the wash.
- Load glasses between the tines, not straddling them.
- Move the rack in and out slowly to avoid slamming the dishware together.
- Make sure not to load dishware so high that the upper impeller could strike them.
- Do not overload the dishwasher.

STAINS AND DISCOLORATIONS

Stains or discoloration on dishware could be caused by a number of things:

- Too much iron or manganese in the water can cause yellow or brown marks on your dishware. You should consider installing a water filtering system.
- Coffee and tea stains usually have to be removed by hand washing. Be sure to rinse these items thoroughly before putting them in the machine so there is no bleach residue on the dishware.



Troubleshooting

If you should experience a problem with your dishwasher, you should review the following list of frequently encountered situations. Even though the product is under warranty, if the problem is not caused by defective product workmanship or materials, you will be charged for a service call. If you're still not sure, contact **Ecomiser** regional agent before you call a service technician.

THINGS TO CONSIDER

- Always use fresh detergent.
- The amount of detergent needed for dishware depends on the hardness of the water in your area. Contact your local utility company to learn the water hardness in your area.
- Make sure the machine is level.
- The length of the dishwasher cycle may run longer if the temperature of the water entering the machine is below **59°F/15°C**. The machine runs longer because it heats the water to the proper temperature by the pre-set program.

DRAIN

- Make sure that the cycle is complete before you open the dishwasher. If not, allow it to complete and check again.
- Check the drain area for blockage.
- Check for a kink in the drain hose.

WATER FILL

- Make sure the water supply is turned on.
- Make sure the dishwasher is turned on and the door is closed securely.
- Check for crimps in the water feed line.
- Make sure the water inlet valve is not clogged.

DOES NOT START

- Make sure the dishwasher is turned on and the door is closed securely.
- Check that the water supply is connected properly and the water is turned on.
- Make sure the power cord is properly connected into the power supply box.
- Check your fuse box for a blown fuse or tripped circuit breaker.

CHECKLIST

Nonconformity	Check	Corrective Action
Is the power not coming on?	Check breaker. Did you press the power button?	Turn the breaker on Press the power button
No water supply	Is the water supply valve open?	Turn the water supply valve on
Makes a lot of noise?	Is the machine level to the ground? Is the spray arm touching the plates?	Install the machine parallel to the ground Do not let the nozzle touch the machine
No drain?	Is the drain hose bent? Is the drain higher than the water level?	Make sure the hose isn't bent Make sure the drain is installed at the bottom level
Poor washing?	Are the impellers clogged? Are the impellers not rotating? Is the dishware too close together? Are you out of detergent? Are dried food bits stuck to the dishware?	Clean up impeller nozzles Do not load dishware too high Do not load dishware too close Refill the detergent Rinse off the dried food bits before putting into the machine
Poor rinsing?	Are there stains on the dishware Is the dishware slippery? Poor drying performance?	Check the temperature Check the amount of rinse detergent Check the temperature
Too much foaming?	Did you use the proper detergent? Is the wash temperature too low?	Use the proper detergent for the machine After confirming the water supply line, check the temperature



Customer Service

PRODUCT WARRANTY

In no event shall the Ecomiser SR-04 / SR-04T model be responsible for any incidental or consequential damages.

Some states will not allow the exclusion or limitation of incidental or consequential damages, so this exclusion or limitation may not apply to you. This warranty gives you specific legal rights and you may also have other rights which vary from state to state.

For warranty service, contact the dealer from whom you purchased the commercial dishwasher or an authorized The Ecomiser SR-04 / SR-04T model service agent. Service will be provided during normal business hours. Should you have a service problem that cannot be resolved locally, contact The Ecomiser SR-04 / SR-04T model service center. Before calling for service regarding a warranty issue, have your serial number ready for reference.

TRANSPORT AND SHIPPING

Cosmetic damage must be reported to your dealer immediately before accepting order. After unpacking the dishwasher, thoroughly check it for cosmetic damage.

- Observe any notices on the crating material that pertain to shipping.
- Use care when transporting the equipment.
- As you unpack the equipment, check that all components shown on the shipping invoice are present and intact. Be sure to check for shipping damage. If shipping damage is present, call the dealer, providing full details, serial number and extent of damage present, and note on shipping documents the damage, before signing.
- In NO EVENT should a damaged appliance be installed or operated.

Warranty is as follows:

Two-year parts, one-year labor from date of purchase. _____

Service must be provided by an authorized **Ecomiser** service agent during normal working hours.

Ecomiser WILL NOT PAY FOR:

Service calls to:

- Correct the installation of the commercial dishwasher.
- Repair damage due to shipment, delivery, installation, misuse or abuse
- Replace fuses or damage due to incorrect field wiring.
- Correct plumbing, including drain problems related to improper installation
- Clean or service plugged drain lines
- Repair and/or replace parts for failure of product if the commercial dishwasher is used for anything other than commercial use.
- Damage resulting from accident, fire, floods, acts of nature, alteration, misuse, abuse, improper installation, or installation not in accordance with local electrical or plumbing codes.
- Repair labor costs for commercial dishwashers operated outside the area of Ecomiser 's regional service agents
- Pickup and delivery
- The Ecomiser SR-04 / SR-04T models are designed to be repaired in the user's place.

Annex 1: SR-04 Block Diagram

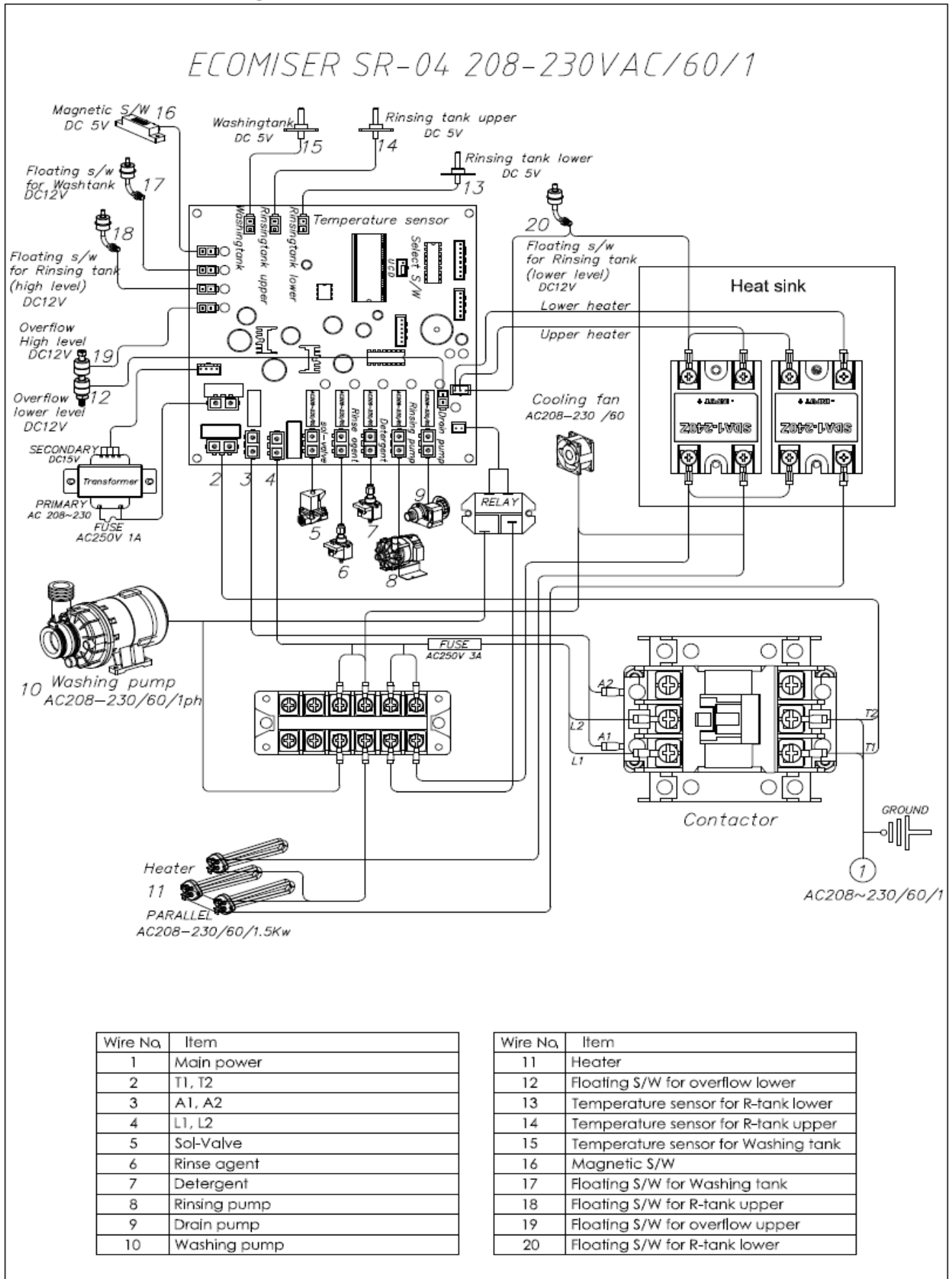

Annex 2: SR-04T Block Diagram

